

Reducer

RCU, RC



Description

Pressed, concentric reducer to meet demands for short installation length with low pressure drop and low internal noise generation.

Pressure drop, see graphs on page 93.

RCU- Eurovent certified Lindab Safe fitting with gasket.
RC- Lindab Vent fitting without gasket.

Dimensions

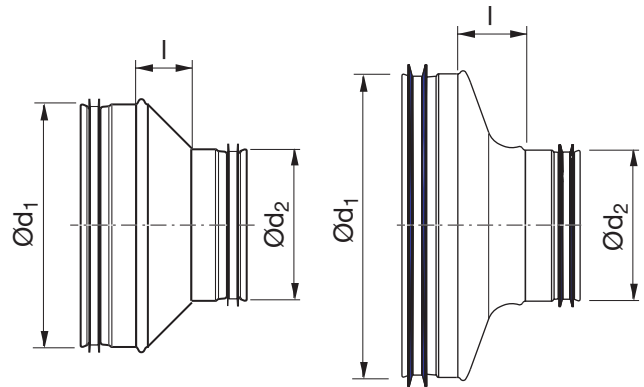

Ød ₁ nom	Ød ₂ nom	l mm	m kg
80	63	18	0,12
100	63	30	0,17
100 *	80	26	0,18
125 *	80	36	0,16
125 *	100	27	0,21
150 *	100	41	0,20
150 *	125	31	0,15
160	80	55	0,31
160 *	100	46	0,17
160 *	125	35	0,22
160	150	22	0,26
180	100	55	0,24
180	125	40	0,37
180	150	27	0,29
180	160	20	0,26
200 *	100	46	0,22
200 *	125	55	0,30
200	150	37	0,37
200 *	160	39	0,29
200	180	26	0,35
224	150	48	0,53
224	160	44	0,53
224	180	34	0,48
224	200	24	0,45
250	125	70	0,62
250	150	62	0,60
250 *	160	60	0,46
250	180	47	0,59
250 *	200	42	0,46
250	224	29	0,57
300 *	200	59	0,64
300	250	34	0,71

Ordering example

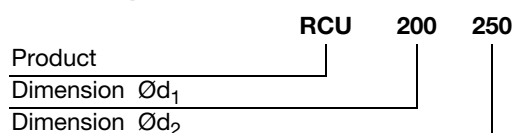

Reducer

RCU, RC

$\text{\O}d_1$ nom	$\text{\O}d_2$ nom	l mm	m kg
315	160	91	0,86
315 *	200	74	0,72
315 *	250	50	0,65
355	250	69	1,08
355	315	33	0,99
400	200	118	1,37
400	250	94	1,38
400	315	54	1,29
500 **	250	128	2,30
500	315	95	1,90
500	400	68	1,76
630 **	315	160	3,37
630 **	400	118	3,17
630 **	500	68	2,89

* With stream-lined transition

** Hand made

Reducers

RCU, RCFU

Technical data

1 dimension step

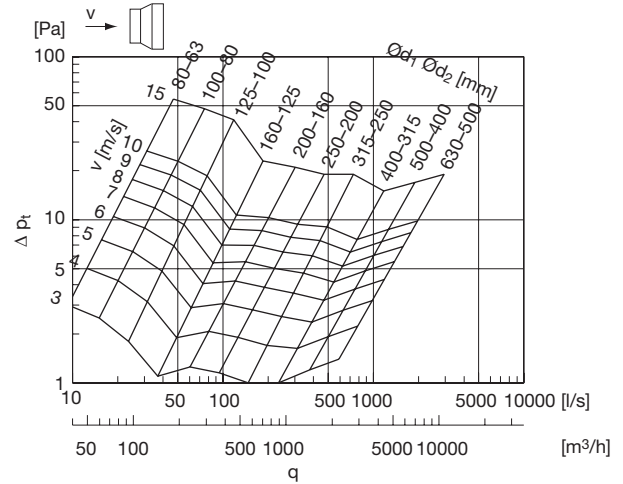
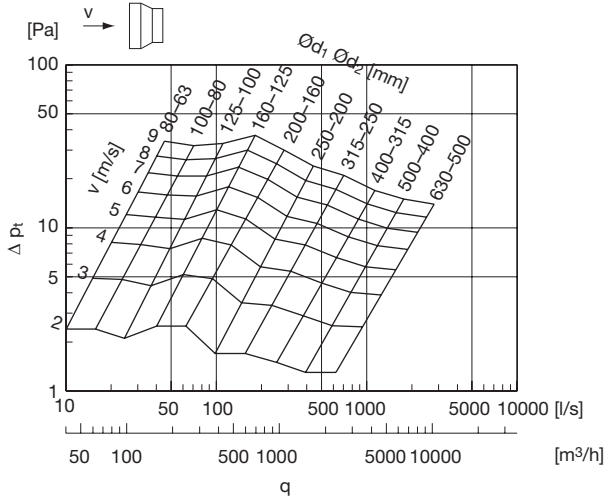

2 dimension steps

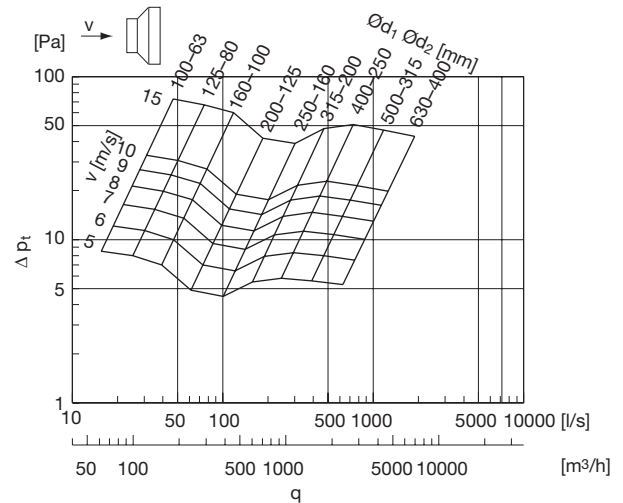
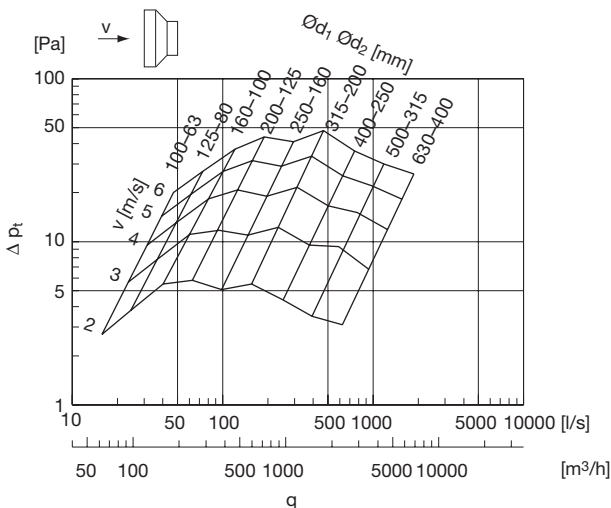

3 dimension steps

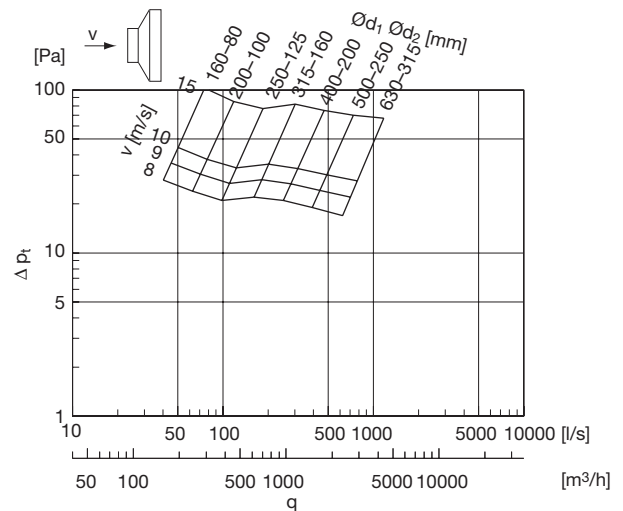
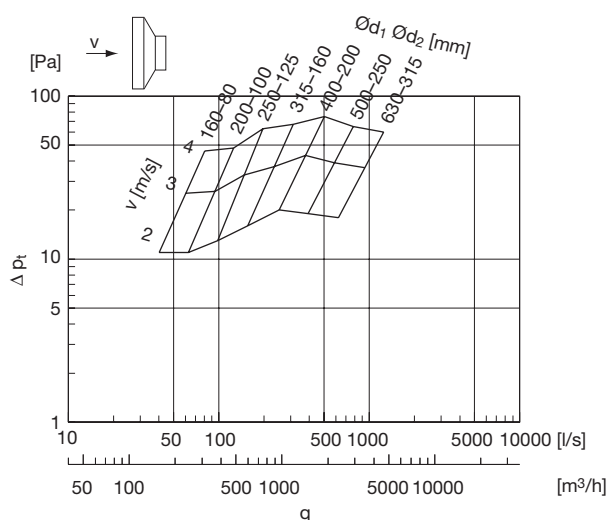

- 1
- 2
- 3
- 4
- 5
- 6
- 7
- 8
- 9
- 10
- 11
- 12
- 13
- 14
- 15
- 16
- 17
- 18